

Turbo Vacuum Oven

SVO-5-T

PART ID: CTVT522-H



Capacity	4.88 cu.ft. (138 liters)
Interior Dimensions (W x D x H)	18" x 26" x 18" 457 x 660 x 457 mm
Exterior Dimensions (W x D x H)	29" x 52" x 69.2" 737 x 1321 x 1758 mm
Unit Weight	633 lb (287 kg)
Shipping Weight	950 lb (431 kg)
Shelves	3 SST Standard, 6 Maximum
Maximum Weight Per Shelf	50 lb / 22.7 kg
Permitted Total Load	200 lb / 90.7 kg
Standard Door Gasket	Viton Standard
Access Port	1 -KF25, 1 CF2.75
Controls	Watlow F4T
Warranty	2 Year Limited Warranty
Interior Construction	304 series stainless steel
Exterior Construction	20 gauge steel, powder coated
Wall Clearance, Each Side	6.0" (152 mm)
Wall Clearance, Rear	12.0" (305 mm)
Vertical Clearance	12.0" (305 mm)
Electrical, 50/60Hz, AC, 1Ø	
Voltage	220V-240V
Full Load Amps	20
Nominal Power (watts @150°C)	1095
Direct Hardwired	✓
Energy Consumption (kWh/day)	
At 80°C	9.2
At 150°C	16.3
At 220°C	26.3
Temperature Range 20°C above ambient to 220°C	
Heat-Up Time — Minutes to 80°C	68
Heat-Up Time — Minutes to 150°C	125
Heat-Up Time — Minutes to 220°C	177
Operation Vacuum Range	<1.0 X 10 ⁻⁶ Torr
Temperature Uniformity	+/- 6% of Set Point
Temperature Stability	+/- 0.2°C @ 150°C
Vacuum Display Range	3.8e-10 ⁻¹⁰ Torr
Safety Certifications	UL 61010-1, EN 61010-1, CSA 61010-1, CE



We reserve the right to alter specifications at any time.

0740615 6/22

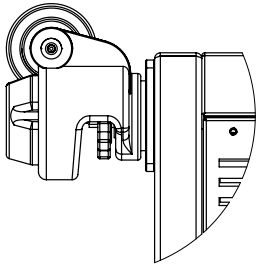

OPTIONAL CASTERS ADD
0.75 IN TO OVERALL HEIGHT
DETAIL A
SCALE 1 : 4

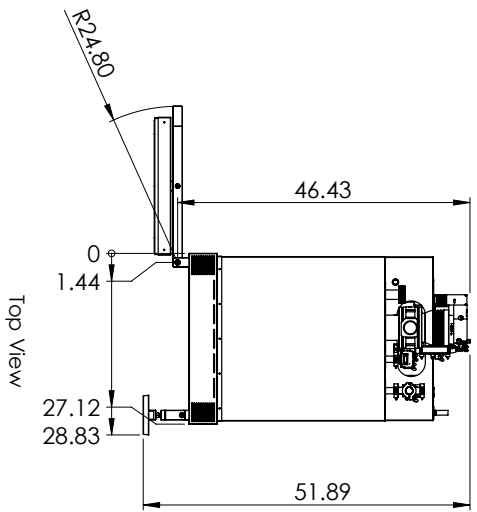

Top View

EXTERNAL MATERIAL:
COLD ROLLED STEEL
POWDER COATED

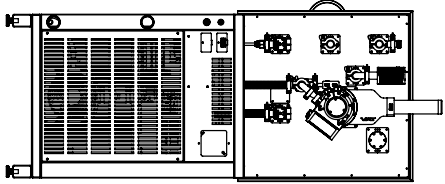
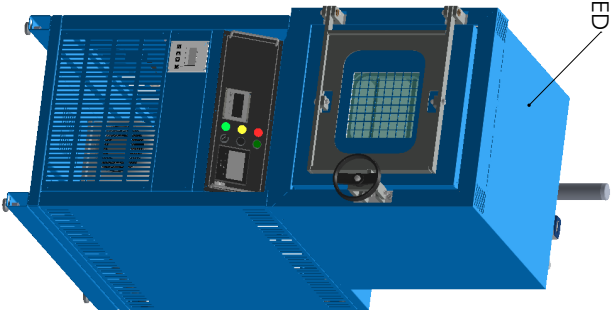

Back View

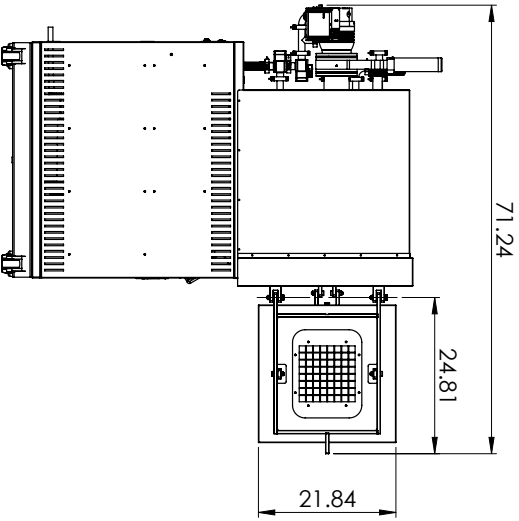

Side View

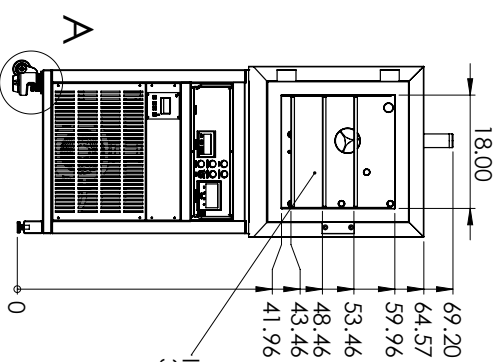

Front View (Door Not Shown)

INTERNAL MATERIAL:
300 SERIES STAINLESS STEEL

				Cascade TEK Solutions, Inc. 4001 East Plano Parkway, Ste 200 Plano, TX 75074 www.cascadetek.com	
PROPRIETARY AND CONFIDENTIAL THE INFORMATION CONTAINED IN THIS DRAWING IS THE SOLE PROPERTY OF CASCADE TEK SOLUTIONS, INC. AND IS PART OR AS A WHOLE WITHOUT THE WRITTEN PERMISSION OF Cascade Mfg.	DRAWN GT	NAME GT	DATE 1/15/2020	MODEL: SVO-5-T	REV A
SIZE B	DWG. NO. 9101016	SCALE: 1:20	WEIGHT:	SHEET 1 OF 4	